

US TYPE FORGED SHOULDER NUT EYE BOLTS G277

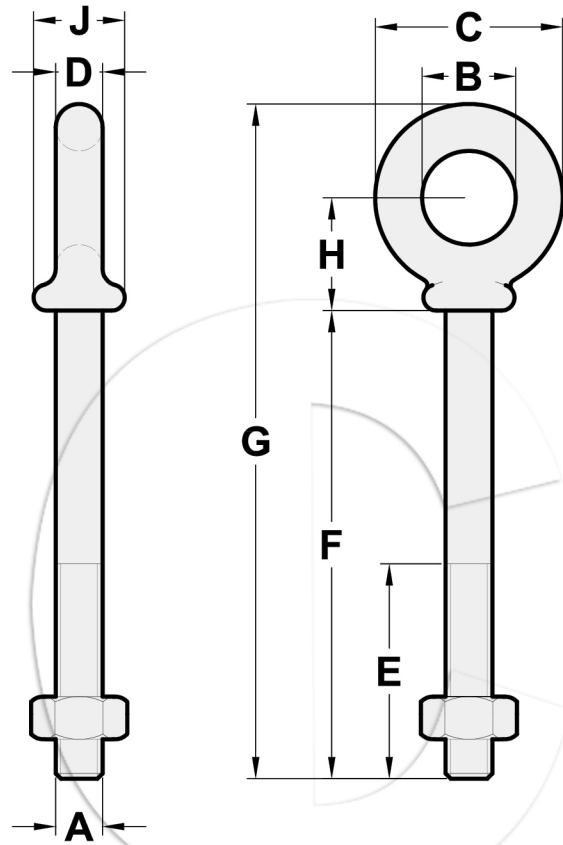

Size (in.)	Working Load Limit (lbs.)	Weight Per 100 (lbs.)	Dimensions (in.)								
			A	B	C	D	E	F	G	H	J
1/4 x 2	650	6.6	0.25	0.5	0.88	0.19	1.5	2	2.94	0.5	0.47
1/4 x 4	650	9.1	0.25	0.5	0.88	0.19	2.5	4	4.94	0.5	0.47
5/16 x 2-1/4	1200	12.5	0.31	0.62	1.12	0.25	1.5	2.25	3.5	0.69	0.56
5/16 x 4-1/4	1200	18.8	0.31	0.62	1.12	0.25	2.5	4.25	5.5	0.69	0.56
3/8 x 2-1/2	1550	21.4	0.38	0.75	1.38	0.31	1.5	2.5	3.97	0.78	0.66
3/8 x 4-1/2	1550	25.3	0.38	0.75	1.38	0.31	2.5	4.5	5.97	0.78	0.66
1/2 x 3-1/4	2600	42.6	0.5	1	1.75	0.38	1.5	3.25	5.12	1	0.91
1/2 x 6	2600	56.8	0.5	1	1.75	0.38	3	6	7.88	1	0.91
5/8 x 4	5200	68.6	0.62	1.25	2.25	0.5	2	4	6.44	1.31	1.12
5/8 x 6	5200	102.4	0.62	1.25	2.25	0.5	3	6	8.44	1.31	1.12
3/4 x 4-1/2	7200	144.5	0.75	1.5	2.75	0.62	2	4.5	7.44	1.56	1.38
3/4 x 6	7200	167.5	0.75	1.5	2.75	0.62	3	6	8.94	1.56	1.38
7/8 x 5	10600	225	0.88	1.75	3.25	0.75	2.5	5	8.46	1.84	1.56
1 x 6	13300	366.3	1	2	3.75	0.88	3	6	9.97	2.09	1.81
1 x 9	13300	422.5	1	2	3.75	0.88	4	9	12.97	2.09	1.81
1-1/4 x 8	21000	650	1.25	2.5	4.5	1	4	8	12.72	2.47	2.28
1-1/4 x 12	21000	795	1.25	2.5	4.5	1	4	12	16.72	2.47	2.28
1-1/2 x 15	24000	1425	1.5	3	5.5	1.25	6	15	20.75	3	2.75