

# DIN1478 RIGGING SCREWS, TYPE EYE AND EYE

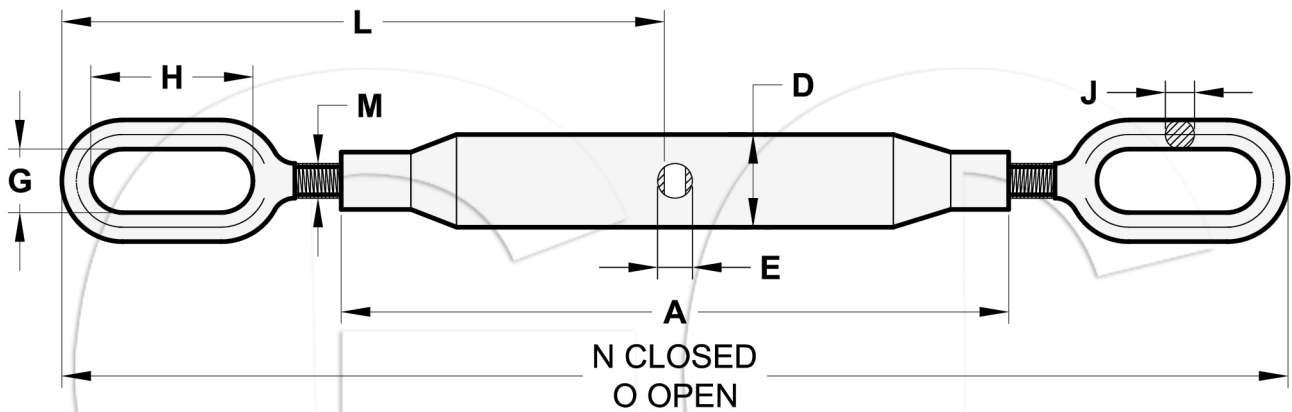

- Meet Performance requirements of DIN1478
- Drop Forged
- Material: Carbon Steel
- Ultimate Load at 4 Times the Working Load Limit
- Finish: Hot Dip Galvanized or Electro-galvanized
- Packing available with Carton Box or Gunny Bag

Size	Weight (kg)	Dimensions (mm)									
		M	A	D	E	G	J	L	N Closed	O Open	H
M6	0.18	M6×1	110	15	6	8	6	96	197	307	14
M8	0.38	M8×1.25	110	17	8.5	8	8	109	223	333	20
M10	0.43	M10×1.5	125	21	8.5	11	8	127	259	384	25
M12	0.9	M12×1.75	125	25	10.5	14	11	182	369	494	36
M16	1.2	M16×2	170	30	10.5	18	14	194	393	563	40
M20	2.02	M20×2.5	200	33.5	12.5	22	16	204	413	613	55
M22	3.07	M22×2.5	220	33.5	12.5	22	17	248	501	721	55
M24	3.9	M24×3	255	42	12.5	25	19	292	589	844	57
M27	4.97	M27×3	255	42	14.5	28	20	294	593	848	57
M33	6.83	M33×3.5	255	57	16.5	34	25	320	645	900	64
M36	7.94	M36×4	295	63	16.5	36	26	325	655	950	75
M42	14.08	M42×4.5	330	70	20.5	38	27	356	717	1047	84
M48	17.48	M48×5	355	83	20.5	44	37	404	813	1168	94