

US TYPE MALLEABLE WIRE ROPE CLIPS

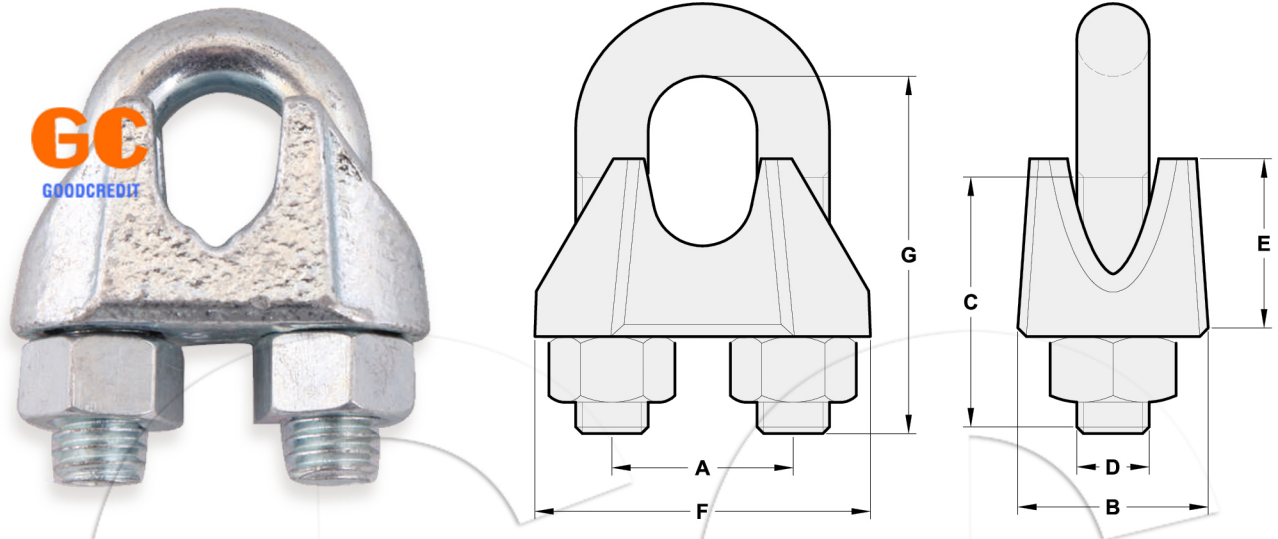

- Meet Performance requirements of Federal Specification FF-C-450D Type 1, Class 2
- Available with Casted Steel
- Finish: Hot Dip Galvanized according to ASTM A153, or Electroplated
- Packing available with Carton Box or Gunny Bag

| Rope Size | | Weight Each (kg) | Dimensions (in) | | | | | | |
|-----------|-------|------------------|-----------------|------|------|------|------|------|------|
| (in) | (mm) | | A | B | C | D | E | F | G |
| 1/16 | 1.5-2 | 0.0136 | 0.38 | 0.45 | 0.45 | 0.15 | 0.45 | 0.69 | 0.65 |
| 1/8 | 3-4 | 0.0182 | 0.50 | 0.56 | 0.50 | 0.18 | 0.50 | 0.94 | 0.81 |
| 3/16 | 5 | 0.0286 | 0.56 | 0.63 | 0.56 | 0.25 | 0.56 | 1.06 | 0.94 |
| 1/4 | 6-7 | 0.0591 | 0.75 | 0.75 | 0.75 | 0.31 | 0.75 | 1.31 | 1.19 |
| 5/16 | 8 | 0.0682 | 0.75 | 0.75 | 0.84 | 0.31 | 0.84 | 1.44 | 1.31 |
| 3/8 | 9-10 | 0.0955 | 0.88 | 0.88 | 1.00 | 0.38 | 1.00 | 1.63 | 1.63 |
| 7/16 | 11 | 0.1682 | 1.06 | 1.06 | 1.19 | 0.44 | 1.19 | 1.88 | 2.00 |
| 1/2 | 12-13 | 0.1682 | 1.06 | 1.06 | 1.19 | 0.44 | 1.19 | 1.88 | 2.00 |
| 9/16 | 14-15 | 0.2682 | 1.25 | 1.28 | 1.38 | 0.50 | 1.38 | 2.09 | 2.31 |
| 5/8 | 16 | 0.2682 | 1.25 | 1.28 | 1.38 | 0.50 | 1.38 | 2.09 | 2.31 |
| 3/4 | 18-20 | 0.3818 | 1.31 | 1.56 | 1.56 | 0.56 | 1.56 | 2.38 | 2.56 |
| 7/8 | 22 | 0.5682 | 1.63 | 1.81 | 1.81 | 0.63 | 1.81 | 2.88 | 3.06 |
| 1 | 24-26 | 0.7545 | 1.88 | 2.00 | 2.00 | 0.63 | 2.00 | 3.00 | 3.44 |
| 1-1/8 | 28-30 | 1.1045 | 2.00 | 2.06 | 2.75 | 0.75 | 2.75 | 3.38 | 4.00 |