

# US TYPE FORGED WIRE ROPE CLIPS G450

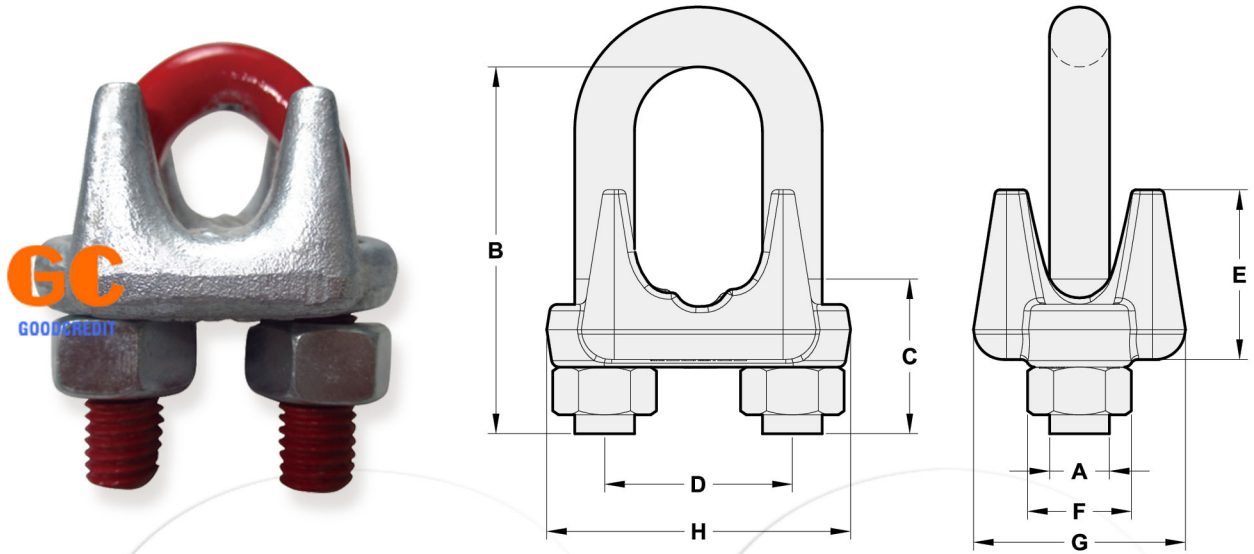

- Meet Performance requirements of Federal Specification FF-C-450D Type 1, Class 1
- Available with Drop Forged Steel
- Finish: Hot Dip Galvanized according to ASTM A153, Powder Coated or Electroplated
- Packing available with Carton Box or Gunny Bag

Rope Size		Standard Package Qty.	Weight Per 100 (lbs)	Dimensions (in)							
(in)	(mm)			A	B	C	D	E	F	G	H
1/8	3-4	100	6	0.22	0.72	0.44	0.47	0.37	0.38	0.81	0.99
3/16	5	100	10	0.25	0.97	0.56	0.59	0.50	0.44	0.94	1.18
1/4	6-7	100	19	0.31	1.03	0.50	0.75	0.66	0.56	1.19	1.43
5/16	8	100	28	0.38	1.38	0.75	0.88	0.73	0.69	1.31	1.66
3/8	9-10	100	48	0.44	1.50	0.75	1.00	0.91	0.75	1.63	1.94
7/16	11	50	78	0.50	1.88	1.00	1.19	1.13	0.88	1.91	2.28
1/2	12-13	50	80	0.50	1.88	1.00	1.19	1.13	0.88	1.91	2.28
9/16	14-15	50	109	0.56	2.25	1.25	1.31	1.34	0.94	2.06	2.50
5/8	16	50	110	0.56	2.25	1.25	1.31	1.34	0.94	2.06	2.50
3/4	18-20	25	142	0.62	2.75	1.44	1.50	1.39	1.06	2.25	2.84
7/8	22	25	212	0.75	3.12	1.62	1.75	1.58	1.25	2.44	3.16
1	24-26	10	252	0.75	3.50	1.81	1.88	1.77	1.25	2.63	3.47
1-1/8	28-30	10	283	0.75	3.88	2.00	2.00	1.91	1.44	2.81	3.59
1-1/4	32-34	10	438	0.88	4.44	2.22	2.34	2.17	1.44	3.13	4.13
1-3/8	36	10	442	0.88	4.44	2.22	2.34	2.31	1.44	3.13	4.19
1-1/2	38	10	544	0.88	4.94	2.38	2.59	2.44	1.63	3.41	4.44
1-5/8	41-42	Buck	704	1.00	5.31	2.62	2.75	2.66	1.81	3.63	4.75
1-3/4	44-46	Buck	934	1.13	5.75	2.75	3.06	2.92	2.00	3.81	5.24
2	48-52	Buck	1300	1.25	6.44	3.00	3.38	3.03	2.00	4.44	5.88
2-1/4	56-58	Buck	1600	1.25	7.13	3.19	3.88	3.19	2.00	4.56	6.38
2-1/2	62-65	Buck	1900	1.25	7.69	3.44	4.13	3.69	2.00	4.69	6.63
2-3/4	68-72	Buck	2300	1.25	8.31	3.56	4.38	4.88	2.00	5.00	6.88
3	75-78	Buck	3100	1.50	9.19	3.88	4.75	4.44	2.38	5.31	7.61
3-1/2	85-90	Buck	4000	1.50	10.75	4.50	5.50	6.00	2.38	6.19	8.38